

Mini Rods

Selectable Tips

RoHS

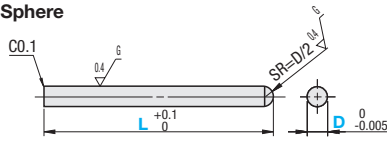
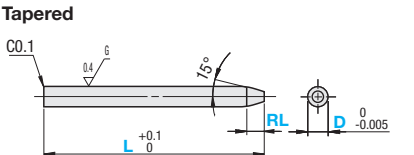
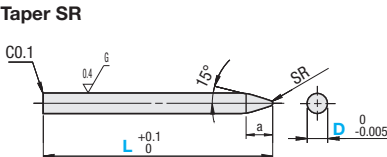

End Shape			Material	Hardness
Sphere	Tapered	Taper SR		
MRSHQ	MRSHT	MRSHR	M2 Tool Steel	58HRC~
MRSSQ	MRSST	MRSST	440C Stainless Steel	56HRC~
MRSQG	MRSQT	-	304 Stainless Steel	-

Sphere Type

Part Number	0.1mm Increment		Unit Price		
	D	L	M2 Tool Steel	440C Stainless Steel	304 Stainless Steel
MRSHQ MRSSQ MRSQG	2.0~2.9	5.0~20.0			
		20.1~50.0			
		50.1~100.0			
	3.0~3.9	5.0~20.0			
		20.1~50.0			
		50.1~100.0			
4.0~5.0	8.0~20.0				
	20.1~50.0				
	50.1~100.0				

Tapered Type

Part Number	0.1mm Increment		RL D-2(RL tan 15°) ≥ 0.2	Unit Price		
	D	L		M2 Tool Steel	440C Stainless Steel	304 Stainless Steel
MRSHT MRSST MRSQT	2.0~2.9	5.0~20.0	0.5~10			
		20.1~50.0				
		50.1~100.0				
	3.0~3.9	5.0~20.0				
		20.1~50.0				
		50.1~100.0				
4.0~5.0	5.0~20.0					
	20.1~50.0					
	50.1~100.0					

Taper SR Type

Part Number	0.1mm Increment		SR ^a (Reference)	Unit Price	
	D	L		M2 Tool Steel	440C Stainless Steel
MRSHR MRSSR	2.0~2.9	8.0~20.0	0.5	2.4~4.1	
		20.1~50.0			
		50.1~100.0			
	3.0~3.9	8.0~20.0			
		20.1~50.0			
		50.1~100.0			
4.0~5.0	8.0~20.0				
	20.1~50.0				
	50.1~100.0				

Ordering Example: Part Number - D - L - RL
MRSHT - D3.5 - L100.0 - RL5

Days to Ship [Configure Online](#)

Price [Configure Online](#)

^a dimensions vary within values listed above according to D dimensions.

Mini Rods

O.D. Tolerance Selectable

RoHS



O.D. Selectable	O.D. Configurable	Material	Hardness
KRSH	KRBSH	M2 Tool Steel	58HRC~
KRSK	KRBSK	W1-9 Tool Steel	58HRC~
KRSD	KRBSD	D2 Tool Steel	60HRC~
KRSS	KRBSS	440C Stainless Steel	56HRC~
KRSG	KRBSG	304 Stainless Steel	-

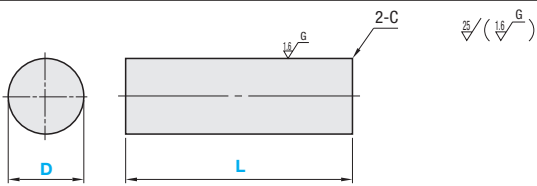

D	Tolerance Selection				
	M	P	G	H	S
0.30	+0.008	+0.012	-0.002	0	0
3.00	+0.002	+0.006	-0.008	-0.010	-
3.01	+0.012	+0.020	-0.004	0	0
5.00	+0.004	+0.012	-0.012	-0.012	-0.01

C Dimension		
or More	or Less	C
D0.3	D0.59	Deburring
D0.6	D5	0.1

L Dimension Tolerance		
or More	or Less	Tolerance
5.0	6.0	±0.1
6.1	30.0	±0.2
30.1	120.0	±0.3
120.1	150.0	±0.5

O.D. Selectable

Part Number	Type	Tolerance Selection	L 0.1mm Increment	Unit Price					
				D	KRSH	KRSK	KRSD	KRSS	KRSG
M G H	KRSK KRSD KRSS KRSG	(D0.3~5) (D0.5~5) (D1~5) (D0.3~5) (D1~5)	5.0~50.0	0.3					
				0.4					
				0.5					
				0.6					
				0.7					
			5.0~60.0	0.8					
				0.9					
				1					
				1.1					
				1.2					
			5.0~70.0	1.3					
				1.4					
				1.5					
				1.6					
				1.7					
5.0~80.0	1.8								
	1.9								
	2								
	2.5								
	3								
5.0~100.0	3.5								
	4								
	4.5								
	5								
	5								

Ordering Example: O.D. Selectable Part Number - L
Type D Tolerance D
KRSH M 0.5 - 50.0

O.D. Configurable Part Number - L - D
Type D Tolerance No.
KRBSH H 0.6 - 30.0 - D0.55

Days to Ship [Configure Online](#)

O.D. Configurable (Specify in 0.01m increment.)

Part Number	Type	Tolerance Selection	No.	L 0.1mm Increment	D 0.01mm Increment	Unit Price				
						KRBSH	KRBSK	KRBSD	KRBSS	KRBSG
M P G H S	KRBSH KRBSK KRBSD KRBSS KRBSG	(No.0.5~5) (No.0.6~5) (No.1.5~5) (No.0.5~5) (No.1.5~5)	5.0~100.0	0.5	0.30~0.49					
				0.6	0.50~0.59					
				1	0.60~0.99					
				1.5	1.00~1.49					
				2	1.50~1.99					
				2.5	2.00~2.49					
				3	2.50~2.99					
				3.5	3.00~3.49					
				4	3.50~3.99					
				4.5	4.00~4.49					
				5	4.50~4.99					

Price [Configure Online](#)

Alterations Part Number - L - (AC, LKC)
KRSHM0.5 - 50.0 - LKC

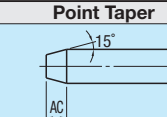
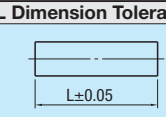
Alterations	Point Taper	L Dimension Tolerance
		
Code	AC	LKC
Spec.	AC: Specify in 0.1mm increment. 0.5 ≤ AC ≤ 10.0 D-2(AC tan 15°) ≥ 0.2 [Ordering Code] AC 5.5	Changes L dimension tolerance within ±0.05 [Ordering Code] LKC
Price Adder		