

# Leveling Mounts - Space Saving

Foot (D dimension) is more compact than that of the conventional leveling mounts.

RoHS

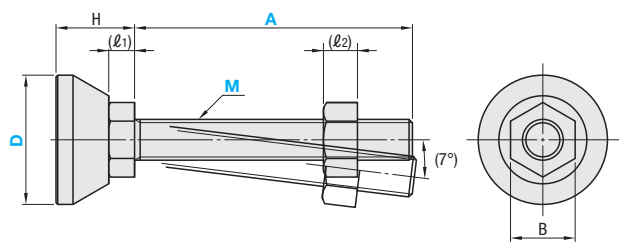



**M** Material: 1018 Carbon Steel  
**S** Surface Treatment: Trivalent Chromate

Screw shafts turns.

| Part Number Type | D  | M (Coarse) | A  |    |     | H    | l1  | l2  | B  | Allowable Vertical Load (kN) | Mass (g) | Unit Price |
|------------------|----|------------|----|----|-----|------|-----|-----|----|------------------------------|----------|------------|
|                  |    |            | 20 | 50 | 100 |      |     |     |    |                              |          |            |
| HNFJN            | 28 | 8          | 20 | 50 | 100 | 17.7 | 5.2 | 6.5 | 13 | 6.5                          | 48       |            |
|                  | 38 | 12         | 30 | 80 | 100 | 23   | 7.4 | 10  | 19 | 13                           | 55       |            |
|                  | 48 | 8          | 20 | 50 | 100 | 20.7 | 5.2 | 6.5 | 13 | 6.5                          | 77       |            |
|                  |    | 12         | 30 | 80 | 100 | 23   | 7.4 | 10  | 19 | 13                           | 90       |            |
|                  | 58 | 8          | 20 | 50 | 100 | 20.7 | 5.2 | 6.5 | 13 | 6.5                          | 121      |            |
|                  |    | 12         | 30 | 80 | 100 | 23   | 7.4 | 10  | 19 | 13                           | 133      |            |

Swivel Type

RoHS



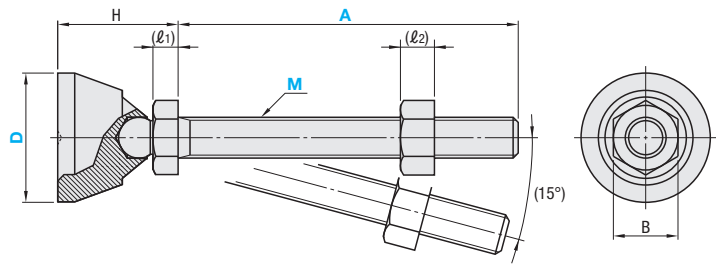

**M** Material: 1018 Carbon Steel  
**S** Surface Treatment: Trivalent Chromate

Screw shafts turns.

| Part Number Type | D  | M (Coarse) | A  |    |     | H    | l1  | l2  | B  | Allowable Vertical Load (kN) | Mass (g) | Unit Price |
|------------------|----|------------|----|----|-----|------|-----|-----|----|------------------------------|----------|------------|
|                  |    |            | 20 | 50 | 100 |      |     |     |    |                              |          |            |
| HNFJR            | 28 | 8          | 20 | 50 | 100 | 28.2 | 5.2 | 6.5 | 13 | 6.5                          | 50       |            |
|                  | 38 | 12         | 30 | 80 | 100 | 35.4 | 7.4 | 10  | 19 | 13                           | 59       |            |
|                  | 48 | 8          | 20 | 50 | 100 | 33.2 | 5.2 | 6.5 | 13 | 6.5                          | 73       |            |
|                  |    | 12         | 30 | 80 | 100 | 35.4 | 7.4 | 10  | 19 | 13                           | 85       |            |
|                  | 58 | 8          | 20 | 50 | 100 | 33.2 | 5.2 | 6.5 | 13 | 6.5                          | 115      |            |
|                  |    | 12         | 30 | 80 | 100 | 35.4 | 7.4 | 10  | 19 | 13                           | 129      |            |

Ordering Example: Part Number - M - A  
HNFJR48 - 12 - 80

Price [Configure Online](#)

Days to Ship [Configure Online](#)

# Leveling Mounts

## Swivel Type / Tapped Socket Type

Swivel Type

RoHS



**LEMNT** (Steel)  
**LEMNS** (Stainless Steel)

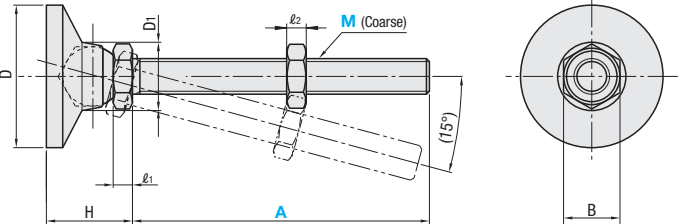

**M** Material: 1018 Carbon Steel  
**S** Surface Treatment: Trivalent Chromate

Tilttable in all 360° directions.

| Type  | Pad                 |                     | Thread, Nut         |                     |
|-------|---------------------|---------------------|---------------------|---------------------|
|       | M Material          | S Surface Treatment | M Material          | S Surface Treatment |
| LEMNT | 1045 Carbon Steel   | Trivalent Chromate  | 1018 Carbon Steel   | Trivalent Chromate  |
| LEMNS | 304 Stainless Steel | -                   | 304 Stainless Steel | -                   |

| Part Number Type        | M-A    | D  | D1 | H  | l1  | l2 | B  | Allowable Vertical Load (kN) | Mass (g) | Unit Price |       |
|-------------------------|--------|----|----|----|-----|----|----|------------------------------|----------|------------|-------|
|                         |        |    |    |    |     |    |    |                              |          | LEMNT      | LEMNS |
| LEMNT (Steel)           | 10-75  | 32 | 21 | 22 | 6   | 8  | 17 | 11.0                         | 342      |            |       |
|                         | 10-100 |    |    |    |     |    |    |                              | 351      |            |       |
|                         | 12-75  | 48 | 23 | 29 | 7.5 | 10 | 19 | 16.0                         | 378      |            |       |
| LEMNS (Stainless Steel) | 16-100 |    |    |    |     |    |    |                              | 390      |            |       |
|                         | 16-130 | 64 | 27 | 32 | 10  | 13 | 24 | 28.3                         | 430      |            |       |
|                         |        |    |    |    |     |    |    |                              | 445      |            |       |

Ordering Example: Part Number LEMNT16-130

Days to Ship [Configure Online](#)

Price [Configure Online](#)

Swivel Short Type

RoHS



**FJRP**

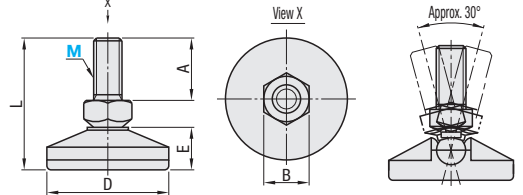

**M** Material: Carbon Steel  
**S** Surface Treatment: Trivalent Chromate

Example

When a leg has an angle



When floor surface is curved



| Main Body | Material            |                   |
|-----------|---------------------|-------------------|
|           | Material            | Surface Treatment |
| Bottom    | 304 Stainless Steel | Polyamide         |

Tapped Socket Type

RoHS



**LEMN** (Nylon)  
**LEMT** (Steel)  
**LEMS** (Stainless Steel)

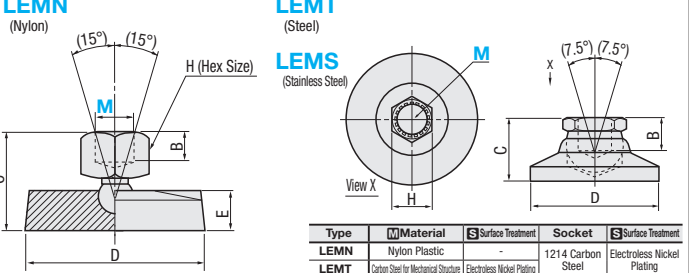

**M** Material: 1018 Carbon Steel  
**S** Surface Treatment: Trivalent Chromate

Example

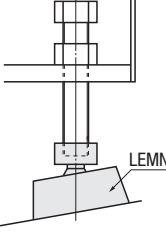

| Type | M Material                            | S Surface Treatment        | Socket              | S Surface Treatment        |
|------|---------------------------------------|----------------------------|---------------------|----------------------------|
| LEMN | Nylon Plastic                         | -                          | 1214 Carbon Steel   | Electroless Nickel Plating |
| LEMT | Carbon Steel for Mechanical Structure | Electroless Nickel Plating | 303 Stainless Steel | Plating                    |
| LEMS | 303 Stainless Steel                   | -                          | 303 Stainless Steel | -                          |

| Part Number Type | M (Coarse) | A    | L  | D  | B    | E    | Allowable Vertical Load (kN) | Mass (g) | Unit Price |
|------------------|------------|------|----|----|------|------|------------------------------|----------|------------|
|                  |            |      |    |    |      |      |                              |          |            |
| 6                | 14         | 31   | 25 | 8  | 9.7  | 0.59 | 11                           |          |            |
| 8                | 19         | 37.5 | 30 | 10 | 11.2 | 1.08 | 21                           |          |            |
| 10               | 20         | 42.5 | 40 | 13 | 13.7 | 1.57 | 38                           |          |            |
| 12               | 25         | 51   | 50 | 17 | 16   | 3.14 | 70                           |          |            |

| Part Number Type | M (Coarse) | B    | C  | D  | E  | H    | Allowable Vertical Load (kN) | Mass (g) | Unit Price |      |
|------------------|------------|------|----|----|----|------|------------------------------|----------|------------|------|
|                  |            |      |    |    |    |      |                              |          | LEMT       | LEMS |
| LEMN (Nylon)     |            |      |    |    |    |      |                              |          |            |      |
| 10               | 9.5        | 39.0 |    |    |    | 16   |                              |          |            |      |
| 12               | 12.7       | 41.0 | 50 | 18 | 19 | 15.9 | 17.1                         |          |            |      |
| 16               | 14.2       | 44.5 |    |    |    | 22   |                              |          |            |      |

Ordering Example: Part Number LEMN10

Days to Ship [Configure Online](#)

Price [Configure Online](#)

| Part Number Type | M (Coarse) | H  | C  | D  | B    | Allowable Vertical Load (kN) | Mass (g) | Unit Price |      |
|------------------|------------|----|----|----|------|------------------------------|----------|------------|------|
|                  |            |    |    |    |      |                              |          | LEMT       | LEMS |
| LEMN (Steel)     |            |    |    |    |      |                              |          |            |      |
| 6                | 10         | 14 | 19 | 4  | 3.1  | 17                           |          |            |      |
| 8                | 13         | 18 | 25 | 8  | 4.1  | 34                           |          |            |      |
| 10               | 17         | 22 | 32 | 10 | 15.4 | 65                           |          |            |      |
| 12               | 19         | 29 | 48 | 11 | 20.5 | 167                          |          |            |      |
| 16               | 22         | 32 | 64 | 11 | 24.6 | 354                          |          |            |      |

Kgf (Load)=Nx0.101972