

Hinge Bases

Center Fulcrum / 4 Mounting Points

RoHS

Type	Material	Surface Treatment
U-Shaped HGCTB HGCNB HGCTM HGCNM HGCTS HGCNS	1045 Carbon Steel 304 Stainless Steel	Black Oxide Electroless Nickel Plating

25 / (6.3 / 1.6)

U-Shaped

T-Shaped

Part Number Type	DH7	W 1mm Increment	H 5mm Increment	A	F	P	X	B	S	T	d2	d1	H1	Unit Price					
														U-Shaped		T-Shaped			
U-Shaped HGCTB HGCTM HGCTS	3	3~6	15~25	28	18	18	5	H+5	8	9	4.5	8	4.5						
	4	4~8	20~30					H+6	10	12									
	5	5~10	25~35					H+8	12	16									
	6	6~12	30~40	32	22	22	5.5	H+10	14	19	5.5	9.5	5.5						
	8	8~16																	
	10	10~18																	
	12	12~30	35~45	45	32	32	6.5	H+12	15	22	6.5	11	6.5						
	13	13~30																	
	14	14~24																	
	15	15~24	40~50	60	40	40	10	H+14	18	25	9	14	9						
	16	16~24																	
	20	20~30																	
	25	25~35		65	45	45		H+17	18	30									

Ordering Example: Part Number - W - H
 HGCTS20 - W20 - H40
 HGCNB12 - W12 - H35

Days to Ship: [Configure Online](#)

Price: [Configure Online](#)

D	Unit Price					
	U-Shaped			T-Shaped		
3	HGCTB	HGCTM	HGCTS	HGCNB	HGCNM	HGCNS
4						
5						
6						
8						
10						
12						
13						
14						
15						
16						
20						
25						

Usage Differences

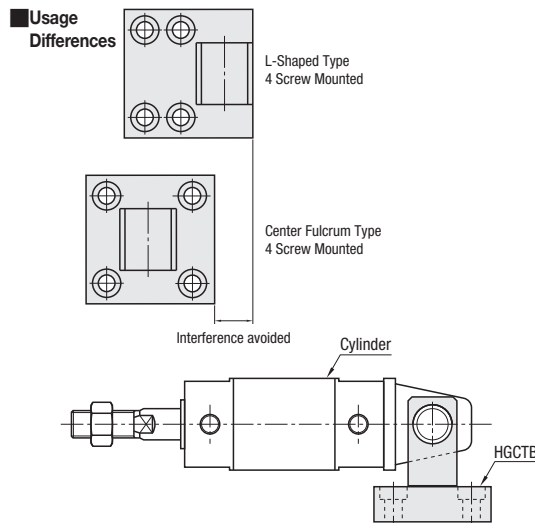

Feature: The hinge base can be used as a cylinder mount.

Thick Hinge Bases

Center Fulcrum / 4 Mounting Points

RoHS

Type	Material	Surface Treatment
U-Shaped HGCJB HGCKB HGCJM HGCKM	1045 Carbon Steel	Black Oxide Electroless Nickel Plating

25 / (6.3 / 1.6)

U-Shaped

T-Shaped

Part Number Type	DH7	T	W 1mm Increment	H 1mm Increment	A	F	P	X	S	d2	d1	H1	C	Unit Price			
														U-Shaped		T-Shaped	
U-Shaped HGCJB HGCJM	4	12	4~8	20~30	32	18	22	5	7.5	4.5	8	4.5	3				
	5	16	5~10											27	5.5		
	6	16	6~12	25~35	28.5	4.75											
		19			27	5.5											
	8	19	8~16	32	6.5												
		22			33.5	5.75											
	10	19	10~20	32	6.5	9.5	5.5	9.5	5.5								
		22			36					7							
	12	22	12~30	30~40	37	6.5											
		25			36	7											
	13	22	13~30	43	8.5	11.5	6.5	11	6.5								
		25			45					7.5							
	15	25	14~30	35~45	43	8.5											
		30			45	7.5											
	16	25	30	45	8.5												
		30			45	7.5											
	20	30	20~35	40~50	48	8.5											
		38			65	48	8.5										
	25	38	25~35	70	45	54	8	16	9	14	9	11					

Ordering Example: Part Number - T - W - H
 HGCJB20 - T30 - W30 - H45
 HGCKB6 - T19 - W10 - H27

Days to Ship: [Configure Online](#)

Price: [Configure Online](#)

List of Diameter (DH7), Thickness (T) and Thickness on One Side

DH7	Hinge Bases Standard (P1481)			Hinge Bases Thick		
	T	Thickness on One Side (T-DH7)/2	T	Thickness on One Side (T-DH7)/2	T	Thickness on One Side (T-DH7)/2
4	9	2.5	12	4	-	-
5	12	3.5	16	5.5	19	7
6	12	3	16	5	19	6.5
8	16	4	19	5.5	22	7
10	16	3	19	4.5	22	6
12	19	3.5	22	5	25	6.5
13	19	3	22	4.5	25	6
14	19	4	22	5.5	25	8
15	22	3.5	25	5	30	7.5
16	22	3	25	4.5	30	7
20	25	2.5	30	5	38	9
25	30	2.5	38	6.5	-	-

Feature: The hole's thickness on one side is selectable by working load.