

STAINLESS STEEL BAFFLE BOARDS

— TAPERED SCREW PLUG TYPE —

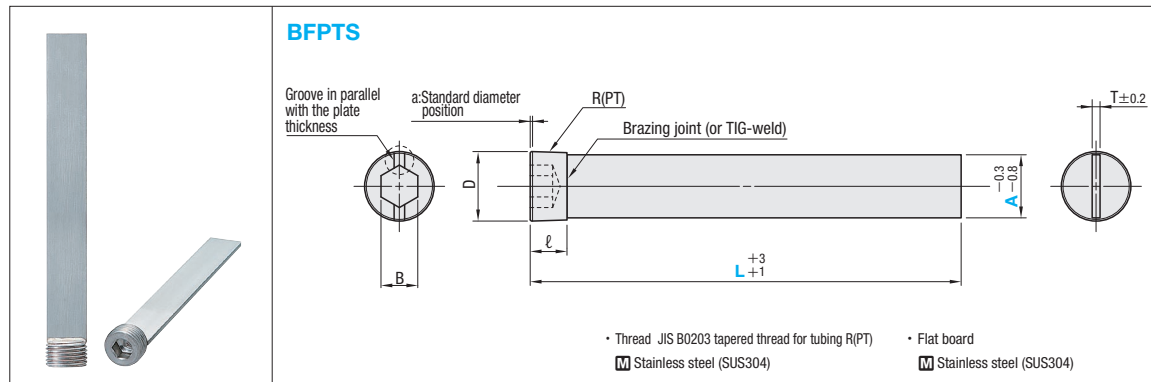

T	D (Reference)	a	l	B	R(PT)	Part Number		L 5mm increments
						Type	A	
3	21.0	0.9	12	10	1/2	BFPTS	18	50~600
	26.4		14	14	3/4		20	
	33.2	1.1	17	17	1		24	
							30	

P Price

Quantity discount rate P.45

Quantity	1~4	5~9	10~14	15~20
Rate	-	5%	10%	15%

To be quoted on price & lead time above Max. Q'ty.

Order

Part Number — L

BFPTS 20 — 200

Days to Ship

3 Days

Delivery days depend on subsidiary. P.45

Express A P.46

ex Example

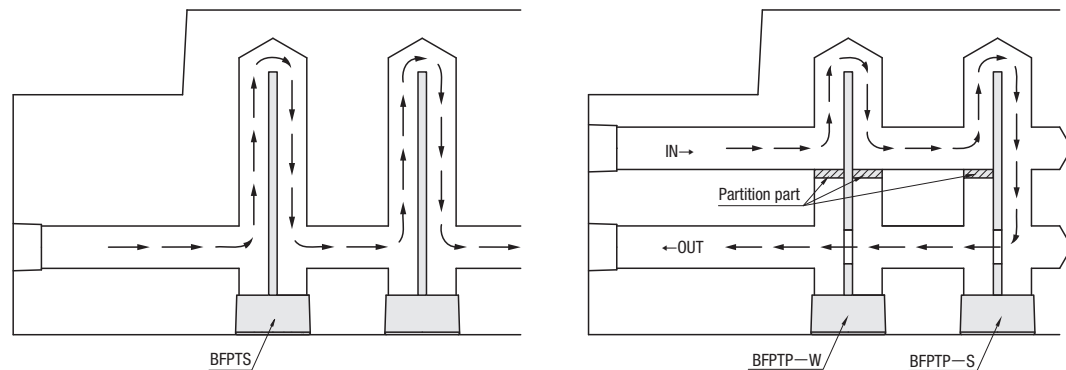

Because the baffle board is made of stainless steel it does not easily rust. Also, because it is integral with the tapered screw plug, maintenance is easy.

If there is an ejector pin or an oblique slide blocking the cooling water hole (transverse hole), partition the inside of the longitudinal water hole, and make a hole mid-way along the baffle board. This will result in a structure in which IN and OUT are in the same plane.

STAINLESS STEEL BAFFLE BOARDS WITH PARTITION FUNCTION

— TAPERED SCREW PLUG TYPE —

Non JIS material definition is listed on P.1359 - 1360

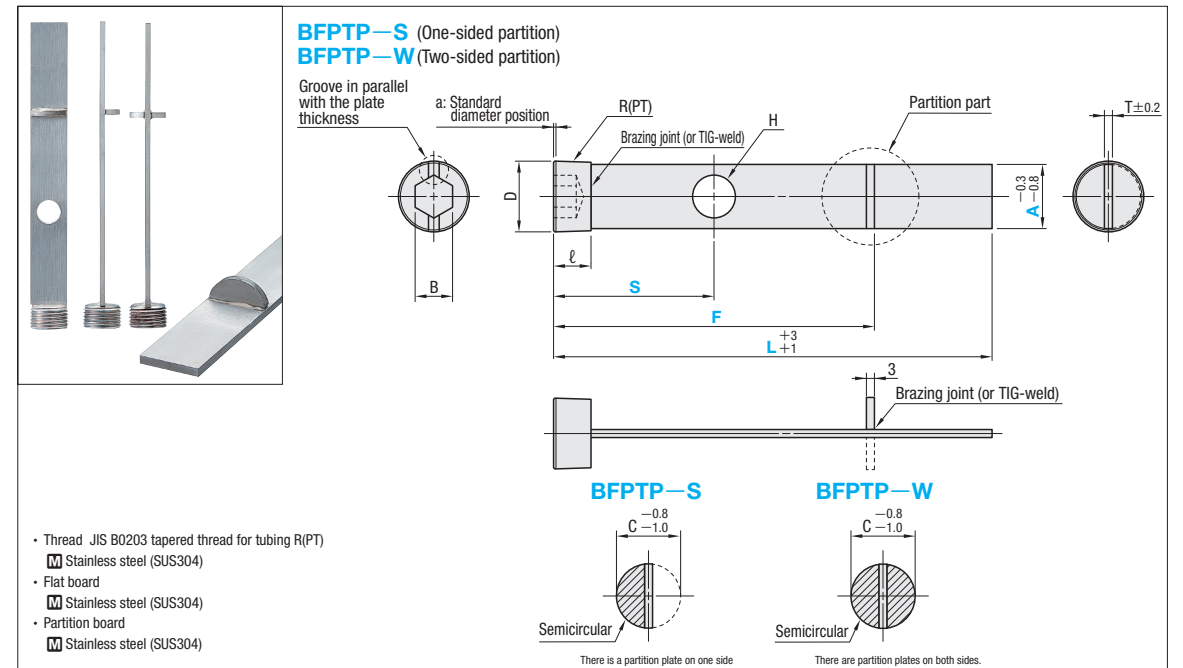

T	D (Reference)	a	l	B	R(PT)	H	C	Part Number		L 10mm increments	F 10mm increments	S 10mm increments
								Type	A			
3	21.0	0.9	12	10	1/2	11	18	BFFTP-S (One-sided partition)	18	100~600	50~590	30~(F-10)
	26.4		14	14	3/4	12	20		20			
	33.2	1.1	17	17	1	18	30		24			

Set the water hole and the partition plate so that they are at least 10mm apart. $(S \leq F - \frac{H}{2} - 13)$

Order

Part Number — L — F — S

BFFTP-S 20 — 500 — F400 — S100

Days to Ship

3 Days

Delivery days depend on subsidiary. P.45

P Price

Quantity discount rate P.45

Quantity	1~4	5~9	10~14	15~20
Rate	-	5%	10%	15%

To be quoted on price & lead time above Max. Q'ty.

Cooling Components
Joints - Hoses
Cooling Inside of Mold