

Dies Steel
SKD61 equivalent
+
Nitrided

STRAIGHT EJECTOR SLEEVES FOR DIE CAST

ⓘ Non JIS material definition is listed on P.1359 - 1360

RoHS

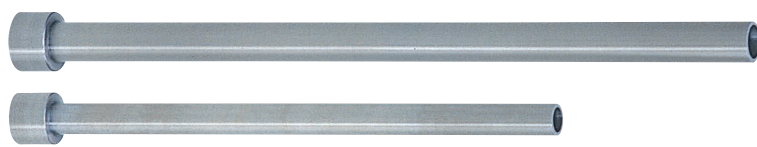

Part Number	V	Applicable center pin shaft diameter tolerance
DESL	H7	-0.01 -0.02 (Details P.1317)

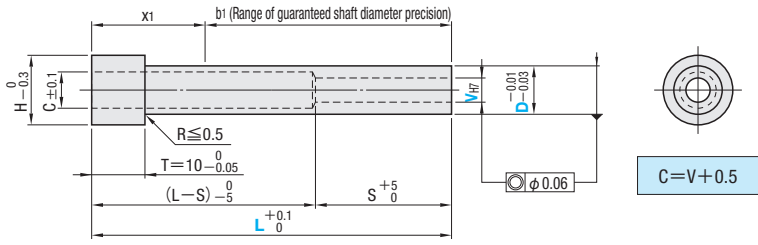

D	D=10	D=12
-0.01	-0.01	-0.01
-0.02	-0.02	-0.03

VH7	V≤3.0	3.5≤V≤6.0	V≥6.5
+0.010	+0.012	+0.015	
0	0	0	

SKD61 equivalent+Nitrided
Surface 900HV
Base material 40±3HRC
b1 (Range of guaranteed shaft diameter precision) (Details P.1309)
x1 max.=40
Range of guaranteed base material hardness (Details P.1311)
Range of guaranteed surface hardness for nitriding (Details P.1311)

L	50.0~100.0	100.1~150.0	150.1~200.0	200.1~250.0	250.1~300.0
S	30	40	50	60	70

Note that the Stepped Center Pin's shaft diameter (D) is too large to fit in the recess (C) of DESL. (Details P.1318)

H	Part Number		L	V
	Type	D		
10	DESL	6	50.0~250.0	2.5~4.0
13		8		2.5~6.0
15		10	50.0~300.0	2.5~8.0
17		12		3.0~10.0

ⓘ DESL: Nitriding may extend to the head as it is applied after dimension V machining.

Order **Part Number** — **L** — **V**
DESL8 — 200.1 — V 4.5

Days to Ship **3** Days
ⓘ Delivery days depend on subsidiary. P.45

Head thickness JIS type P.307 · 311 · 315
T=4, 6, 8

Alterations **Part Number** — **L** — **V** — (KC · WKC · etc.)
DESL8 — 200.1 — V 4.0 — KC 4.5

ⓘ Express services not available for CGX · RGX · CGZ · RGZ.

Alterations	Code	Spec.	1Code
	KC	KC=0.1mm increments D/2 ≤ KC < H/2	Quotation
	WKC	WKC=0.1mm increments D/2 ≤ WKC < H/2	
	KAC KBC	KAC, KBC=0.1mm increments D/2 ≤ KAC < KBC < H/2	
	RKC	RKC=0.1mm increments D/2 ≤ RKC < H/2	
	DKC	DKC=0.1mm increments D/2 ≤ DKC < H/2	
	KGC	KGC=0.1mm increments AG=1° increments D/2 ≤ KGC < H/2, 0 < AG < 360	
	KTC	KTC=0.1mm increments D/2 ≤ KTC < H/2	

Alteration details P.55

Alterations	Code	Spec.	1Code
	TC	TC=0.1mm increments 5.0 ≤ TC < 10, 10 — TC ≤ L max. — L Dimensions L and (L-S) remain unchanged.	
	HC	HC=0.1mm increments D ≤ HC < H In relation to the head diameter tolerance, alteration may create a straight piece with little diameter difference between the head and shaft.	
	CW	Two-step recessing (Makes recess C into two-step and widens it) CW=0.1mm increments W=5mm increments V+1.0 ≤ CW ≤ V max. +0.5 10 ≤ W ≤ L-S-10, W ≤ 200	Quotation
	CGX	CGX=0.1mm increments 0.2 ≤ CGX ≤ 1.5 and CGX ≤ D-V/2 -0.1 Combination with RGX/CGZ/RGZ not available.	Quotation
	RGX	RGX=0.1mm increments 0.3 ≤ RGX ≤ 1.5 and RGX ≤ D-V/2 -0.1 Combination with CGX/CGZ/RGZ not available.	
	CGZ	CGZ=0.1mm increments 0.2 ≤ CGZ ≤ 1.0 and CGZ ≤ D-V/2 -0.1 Combination with CGX/RGX/RGZ not available.	
	RGZ	RGZ=0.1mm increments 0.5 ≤ RGZ ≤ 1.0 and RGZ ≤ D-V/2 -0.1 Combination with CGX/RGX/CGZ not available.	

Price **Quantity discount rate** P.45

Quantity	1~4	5~12	13~19	20~50
Rate	—	5%	10%	15%

ⓘ To be quoted on price & lead time above Max. Q'ty.

Die Cast Parts